

三久玉米用脫粒機

SUNCUE CORN SHELLER



自動分離玉米與玉米穗軸，
同時進行風選，經風選處理後，
脫粒的玉米更乾淨。

Auto-separate corn and cob,
plus aspiration with air blower.

規格 SPECIFICATIONS	
項目Item	機型Model
	SS-135
適用穀物 Application	玉米穗* Corn on cob*
機台尺寸 Dimension 長x寬x高mm LxWxH mm	1,933x1,766x2,548
空機重量 Net Weight 約公斤 Approx. kg	558 含馬達 Including motor
處理量 Capacity 噸/小時 ton/ hr	8~13.5
電壓 Voltage	三相3P, 220V/380V/415V/440V, 50/60Hz
動力 Power Consumption	7.5kW 10HP
脫粒筒長度 Length of Threshing Cylinder mm	1197
脫粒筒轉速 RPM of Threshing Cylinder	720
集粒方式 Kernel Collecting Method	螺旋水平輸送 Horizontal transport via a screw
排穗軸方式 Cob Discharge	輪機排穗軸 Via a rotary device
進料方式 Feeding Method	擱板輸送 Via a slat conveyor

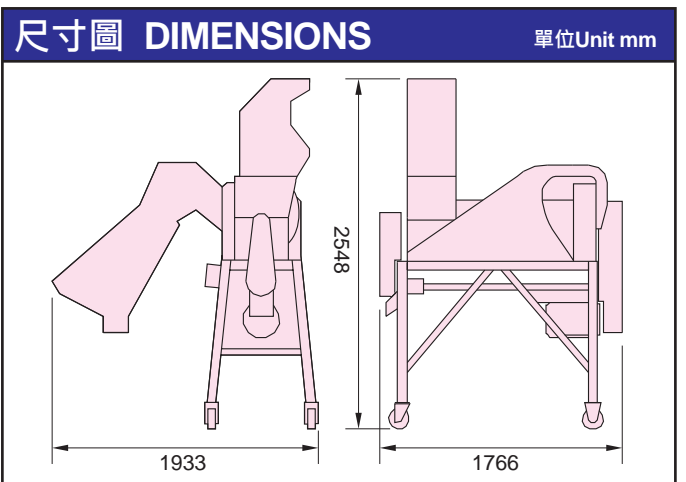

*若需為種子專用，請另洽三久營業單位。

- 進料、出料、排雜輸送裝置及脫粒後的集料筒由客戶自理。
- 圖示及規格僅供參考，實際產品規格以客戶簽署訂單及出貨實物為主。

- *For seed-specific requirements, please contact the SUNCUE sales department.
- The customer is responsible for the feed, discharge, and impurity removal conveyors, as well as the collection cylinder after de-husking.
- The specification and graph are for reference only. Actual specification of SUNCUE product shall be based on the Sales Confirmation which customers sign and delivered products.

